

53112500 Internal	<b>DATA SHEET</b>	
Valid from: 02.05.2025	<b>SKINTOP® MS-M BRUSH 75 plus / 90 / 110 plus</b>	

The SKINTOP® MS-M BRUSH 75 plus / 90 / 110 plus with innovative double lamella insert for easier assembling of cables with large diameter, is a nickel-plated brass cable gland especially designed for copper-screened cables (optimal low-resistance 360°). Suitable to achieve a low-resistance screen contact, strain relief and high protection class.

Application range: automotive systems, conveyor technologies, high power drives, frequency converters.

The SKINTOP® MS-M BRUSH 75 plus / 90 / 110 plus contacts the screen much faster than any other system.

For painted, anodized or powdered coated housings, you will require our EMC counter nut SKINDICHT® SM-PE-M for best contact.



### Component parts:

Gland body	Brass, nickel-plated
Cap nut	Brass, nickel-plated
Double lamellar cage	Polyamide
Sealing rings	CR
Contact brush	Brass wire
O-ring	NBR

### Technical features:

Connecting thread	M75x1,5; M90x2; M110x2 acc. to EN 60423
Protection class	IP68 – 1 bar for M75x1,5 acc. to EN 60529
Temperature range:	-20 °C up to +100 °C

### Approvals:



UL File Nr. 79903 (only M75x1,5)  
DNV (only M75x1,5)

### Norm references:



Creator: T. Dvoulety/PDP Released: DAMU 1/PDP	Document: DB53112500EN Version: 07	Page 1 of 2
--	---------------------------------------	-------------

53112500 Internal	<b>DATA SHEET</b>	
Valid from: 02.05.2025	<b>SKINTOP® MS-M BRUSH 75 plus / 90 / 110 plus</b>	

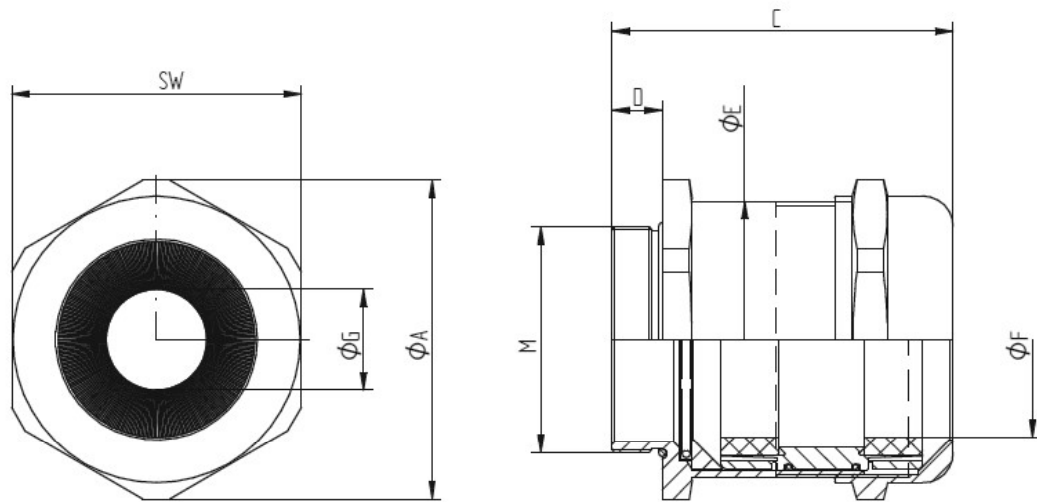

M	SW [mm]	Ø A [mm]	C max. [mm]	D [mm]	Ø E [mm]	Ø F [mm] Klemmbereich	Ø G [mm] über Geflecht	O-Ring [mm]	Artikel-Nr.
M75x1,5	95	105	105,0	15	90	53-63	25-68	65x3	53112501
M75x1,5 plus	95	105	105,0	15	90	58-68	25-68	65x3	53112500
M90x2	115	127	135,5	20	110	66-78	40-78	82x3	53112503
M110x2	135	150	154,0	25	130	76-88	50-88	100x3	53112505
M110x2 plus	135	150	154,0	25	130	86-98	50-98	100x3	53112504

For more information please see our current catalogue. Please do not hesitate to contact our laboratory if there are any questions regarding resistance against aggressive agents and special oil.

Creator: T. Dvoutely/PDP Released: DAMU 1/PDP	Document: DB53112500EN Version: 07	Page 2 of 2
--	---------------------------------------	-------------